



DW8502

High Power LED Driver



CONTENTS

1. GENERAL DESCRIPTION	1
■ Features	1
■ Applications	1
2. BLOCK DIAGRAM	2
3. PIN INFORMATION.....	2
■ Pin Placement.....	2
■ Pin Description.....	2
4. ABSOLUTE MAXIMUM RATINGS	3
5. RECOMMENDED OPERATING CONDITION.....	3
6. ELECTRICAL SPECIFICATION.....	4
7. TYPICAL OPERATING CHARACTERISTICS	5
8. TYPICAL APPLICATIONS CIRCUIT	7
9. DETAILED DESCRIPTIONS	8
■ Setting Output Current.....	8
■ Power Sequence	8
10. PACKAGE DIMENSION	9



1. General Description

DW8502 is an instant On/Off LED driver for high power LED applications. At DW8502 output stage, one regulated current port is designed to provide a uniform and constant current sink for driving LEDs within a large range of V_F variations. DW8502 easily provides users with a consistent current source. User may adjust the output current up to 2.5A through an external resistor R_S , which gives users flexibility in controlling the light intensity of LEDs. In addition, users can precisely adjust LED brightness from 0% to 100% via output enable (EN) with Pulse Width Modulation. DW8502 can accommodate an input voltage up to 40V.

■ Features

- providing a constant output current regardless of input voltage or load voltage changes
- 5V to 40V supply voltage
- adjustable output current up to 2.5A
- Built-in thermal derating circuit
- Available PWM dimming control
- Output current adjusted through an external resistor
- TO-263, TO-220 Package

■ Applications

- LED light bulbs
- Signage and decorative LED lighting
- General lighting of flat panel displays
- RGB backlighting LED driver
- Current stabilizer with DC/DC or AC/DC
- General purpose constant current source



2. Block Diagram

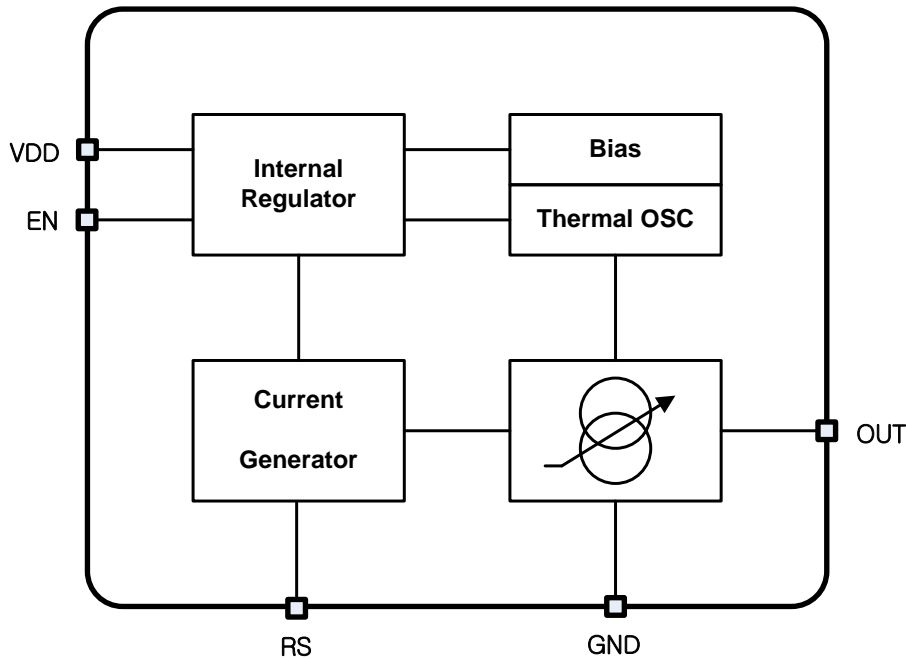

3. Pin Information

■ Pin Placement

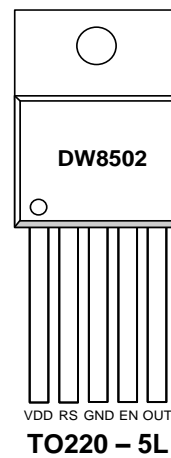
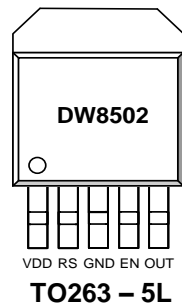

■ Pin Description

No.	Pin Name	Description	Note
1	VDD	Supply Voltage input	
2	RS	Sets output current. Connect a resistor from RS to GND to set the LED bias current	
3	GND	Ground	
4	EN	Output stage enable control pin. If not use dimming, connect to VDD. Dimming control is available by PWM(Pulse width modulation) under 30KHz typically.	
5	OUT	Output pin. Sink current is decided by the current on R_{SET} connected to RS	
6	HS	Heat sink, normally connected GND	



4. Absolute Maximum Ratings⁽¹⁾

Symbol	Parameter		Ratings
VDD	Supply voltage		41V
V _{EN}	Enable voltage		41V
V _{OUT}	Output voltage		23V
V _{RS}	Reference voltage		5V
θ _{JA} ⁽²⁾	Package thermal resistance	TO-263-5L	22.85 °C/W
		SOT-220-5L	62 °C/W
T _{JOPR}	Junction Operating temperature		-40~+125 °C
T _J	Junction temperature		+150 °C
T _{STG}	Storage Temperature		-55~+150 °C

Note (1) Stresses above the max. Values listed here may cause permanent damage to the device. Exposure to absolute maximum rating conditions for extended periods may affect device reliability. Maximum ratings are absolute ratings; exceeding only one of these values may cause irreversible damage to the integrated circuit.

(2) θ_{JA} is measured in the convection at Ta=30 °C on a high effective thermal conductivity test board(4 Layers, 2S2P) of JEDEC 51-7 thermal measurement standard. PCB dimension is 100mmx100mmx1.6mm and 4 layers.

5. Recommended Operating Condition

Symbol	Parameter	Min.	Typ.	Max.	Unit
VDD	Supply voltage	5		40	V
V _{EN}	Enable voltage			40	V
I _{OUT}	Output sink current			2.5	A



6. Electrical Specification

(VDD = 24V, typical values are at TA=+25°C, unless otherwise specified.)

Characteristic	Symbol	Condition	Min.	Typ.	Max.	Unit
Input Supply Voltage	V _{DD}		5	-	40	V
Output Linearity Voltage	V _{OUT_LINE}	V _{DD} =24V, I _{SET} = 300mA,	-	-	3	V
Output Current	I _{OUT}		-	-	2.5	A
Quiescent Current	I _{Q_ON}	EN = 24V	0.8	1	1.5	mA
	I _{Q_OFF}	EN = 0V	85	120	250	uA
EN Input Leakage Current	I _{EN_LIK}		30	45	60	uA
Input High Voltage	V _{IH}		2	-	-	V
Input Low Voltage	V _{IL}		-	-	0.8	V
LED Output Dropout Voltage	V _{DROP}	V _{DD} =40V , I _{SET} =300mA	240	270	300	mV
Thermal Derating	T _D		-	140	-	°C
Thermal Derating Hysteresis	T _{DHYS}		-	15	-	°C
R _{SET} Voltage	V _{SET}		0.58	0.61	0.64	V
Output Current	I _{OUT}	2KΩ	290	305	320	mA

Note : Output dropout voltage : 90% x I_{OUT}



7. Typical Operating Characteristics

($V_{DD} = 12V$, $V_{OUT} = 2V$, typical values are at $T_A = +25^\circ C$, unless otherwise specified.)

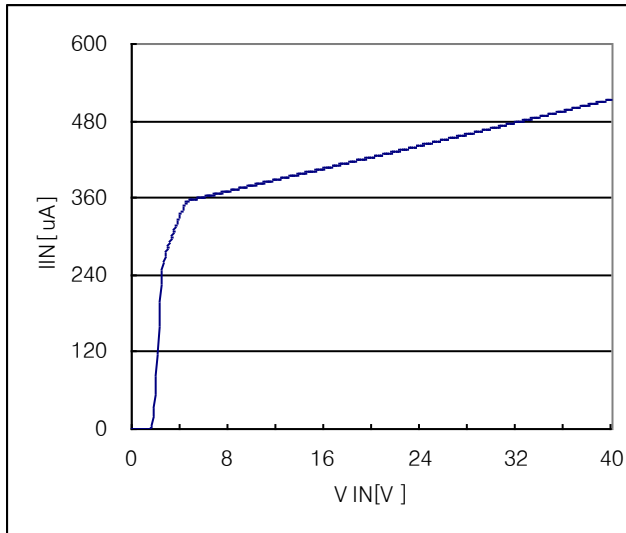

Quiescent vs. VIN

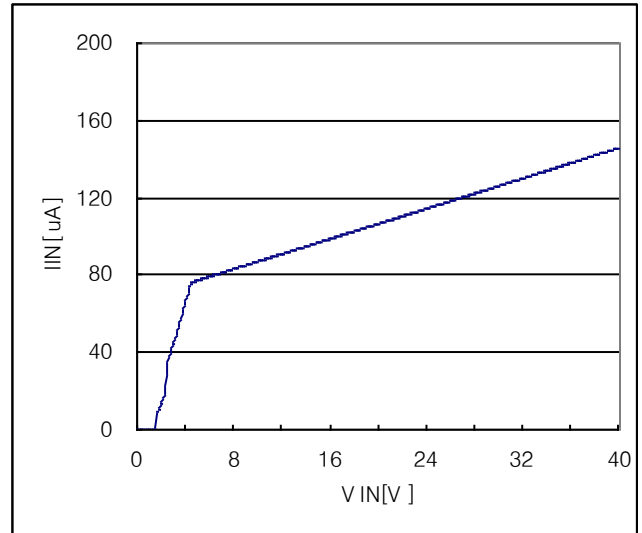

Ishutdown vs. VIN

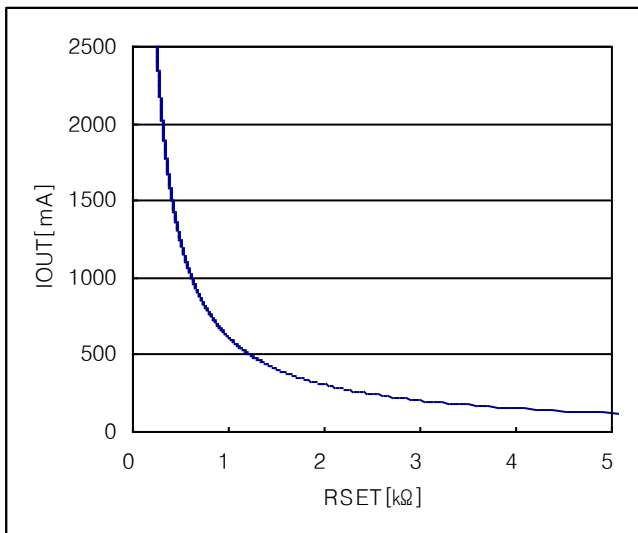

IOUT vs. RSET

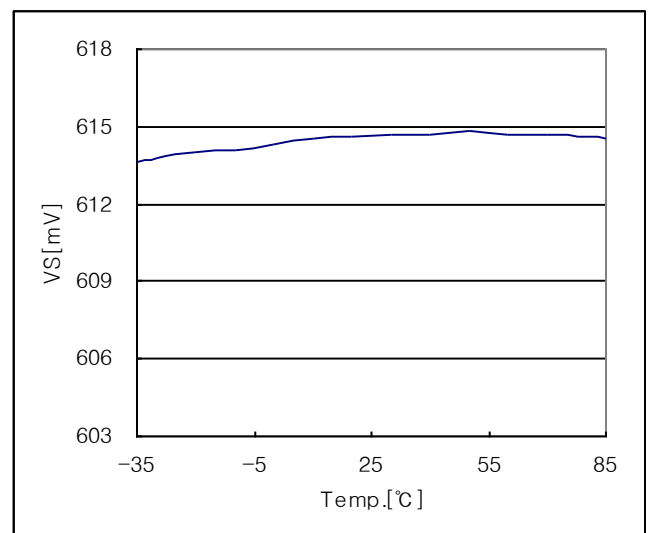

Vreference vs. Temperature



7.1. Typical Operating Characteristics

($V_{DD} = 12V$, $V_{OUT} = 2V$, typical values are at $T_A = +25^\circ C$, unless otherwise specified.)

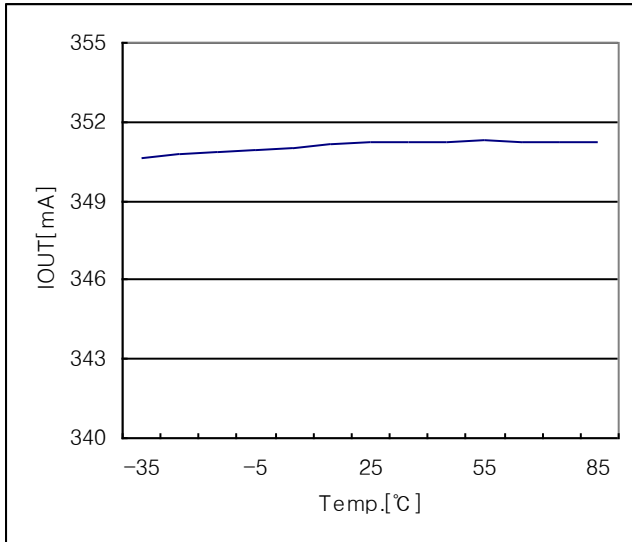

IOUT vs. Temperature

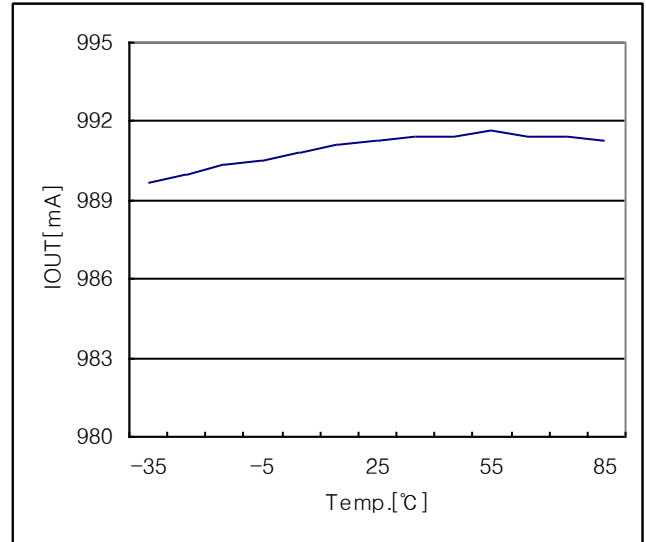

IOUT vs. Temperature

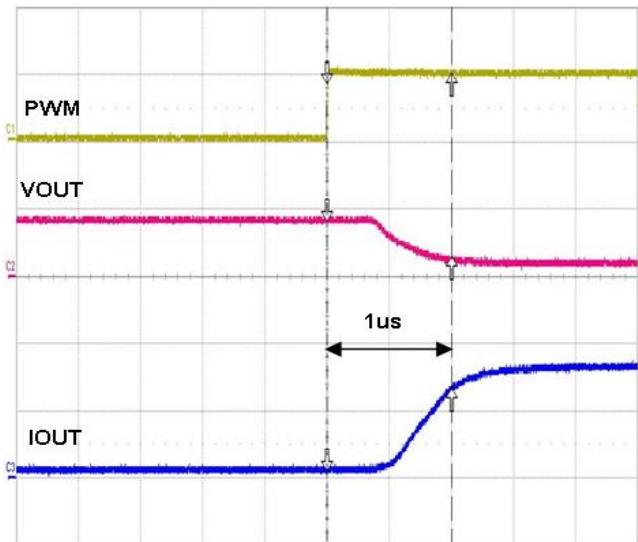

PWM Rising Time

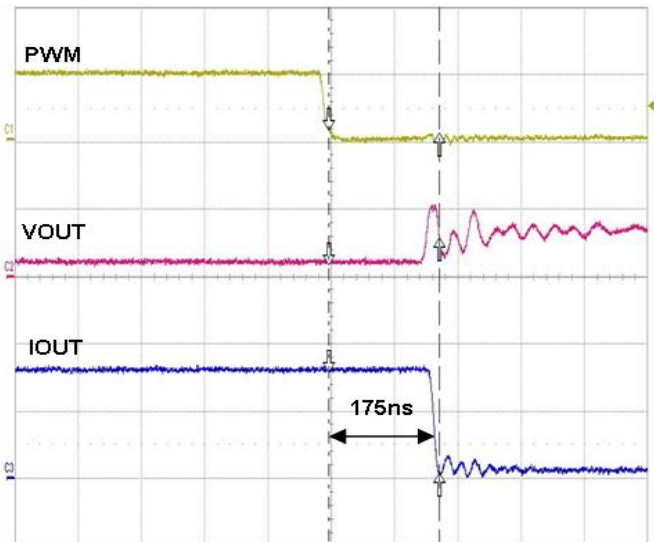

PWM Falling Time



8. Typical Applications circuit

(LED $V_F = 3.3V$, $I_F = 20mA$)

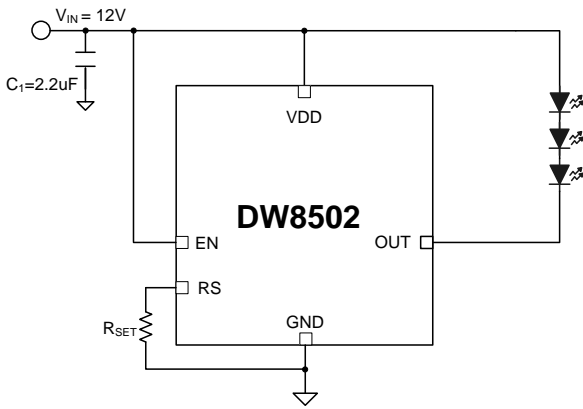

Figure 1. $V_{IN}=12V$

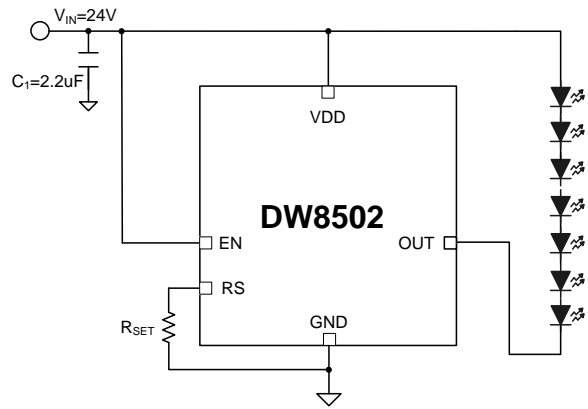

Figure 2. $V_{IN}=24V$

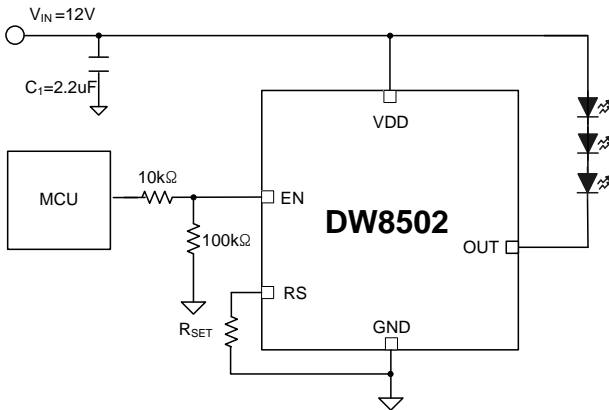

Figure 3. PWM Dimming Typical Application

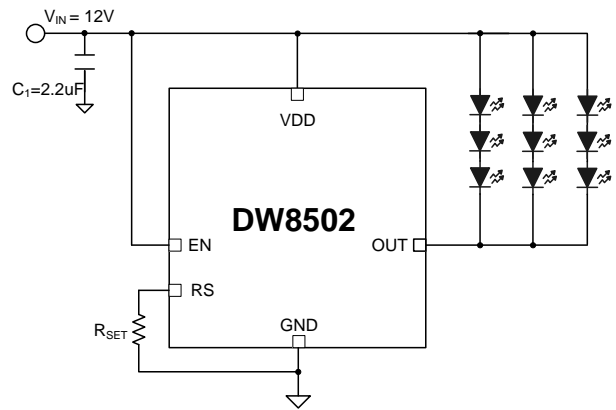

Figure 4. $V_{IN}=12V$, 9 LED

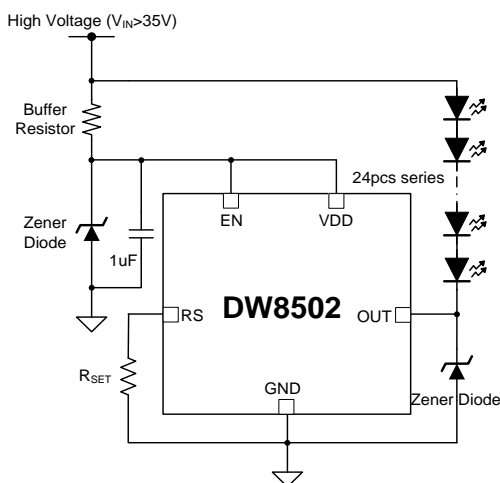

Figure 5. High Voltage Application ($V_{DD} \geq 35V$)



9. Detailed Descriptions

■ Setting Output Current

$$I_{OUT} [mA] = (610[mV]/R_{SET}[ohm]) \times 1000$$

R _{SET} (KΩ)	I _{OUT} (mA)
4	152
2	305
1.22	500
1.02	598
0.76	802
0.68	897
0.61	1000
0.41	1500
0.31	2000
0.24	2500

■ Power Sequence

There is an electrostatic diode between VDD and EN.

When dimming control, It must input EN signal after inputs VDD. (t ≥ 1ms)

If not use Dimming control, EN connect to VDD.

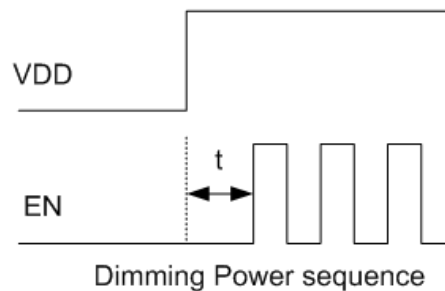

10. Package Dimension

Package Name : TO263-5L
 Package Size : 10.16mm * 14.35mm, Thickness : 4.57mm
 Pin Pitch : 1.7mm

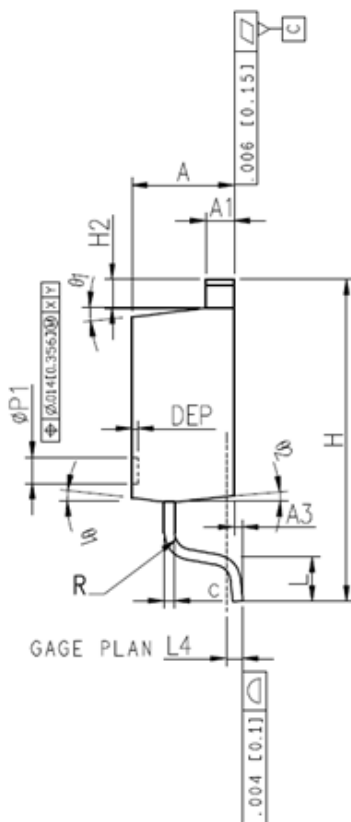
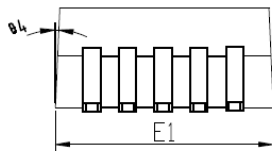
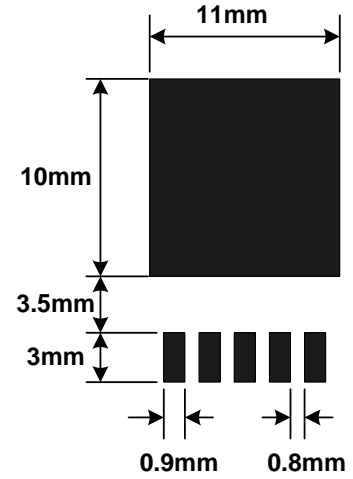
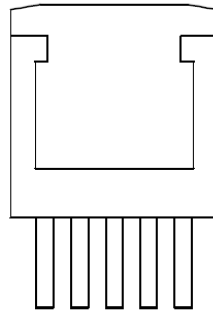
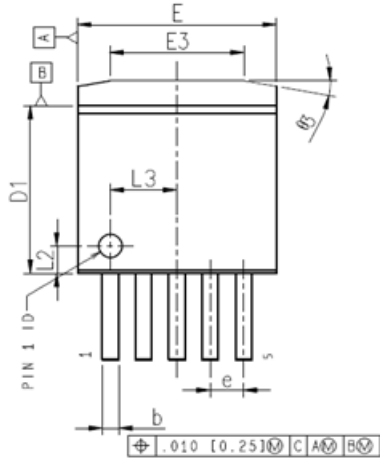

SYMBOL	MM			INCH		
	MIN	NDM	MAX	MIN	NDM	MAX
A	4.45	4.57	4.70	0.175	0.180	0.185
A1	1.22	1.27	1.32	0.048	0.050	0.052
A3	0	-	0.15	0.000	-	0.006
b	0.71	-	0.97	0.028	-	0.038
c	0.38	-	0.76	0.015	-	0.030
D1	8.38	8.70	8.89	0.330	0.343	0.350
E	9.91	10.16	10.39	0.390	0.400	0.410
E1	10.03	10.16	10.54	0.395	0.400	0.415
E3	6.61	6.86	7.11	0.260	0.270	0.280
e	1.70BSC			0.067BSC		
H	-	-	14.35	-	-	0.565
H2	-	-	1.27	-	-	0.050
L	-	1.98	-	-	0.078	-
L2	1.47REF			0.058REF		
L3	3.40REF			0.134REF		
L4	-	0.76	-	-	0.030	-
$\phi p1$	1.07	1.20	1.32	0.042	0.047	0.052
R	-	-	0.76	-	-	0.030
$\theta 1$	-	7°	-	-	7°	-
$\theta 2$	-	3°	-	-	3°	-
$\theta 3$	7°	10°	13°	7°	10°	13°
$\theta 4$	-	3°	-	-	3°	-
DEP	0.10	0.18	0.25	0.004	0.007	0.010



10.1. Package Dimension

Package Name : TO220-5L
 Package Size : 10.26mm * 28.79mm, Thickness : 4.57mm
 Pin Pitch : 1.7mm

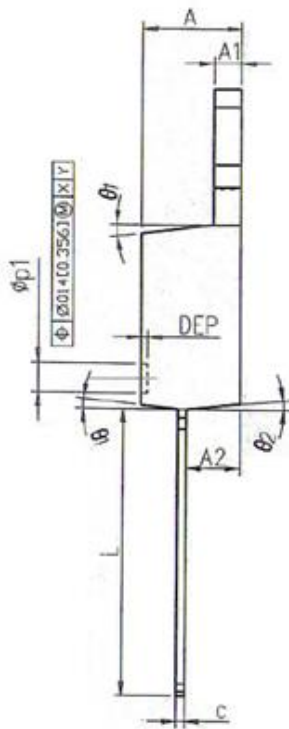
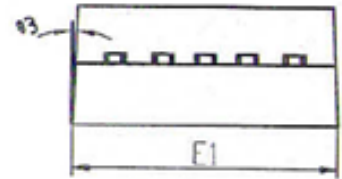
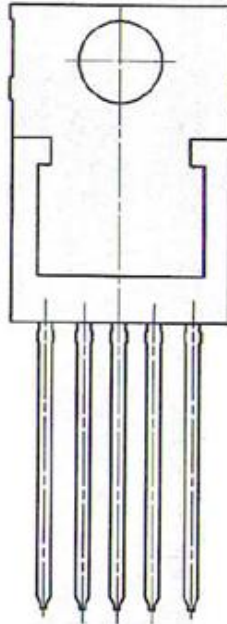
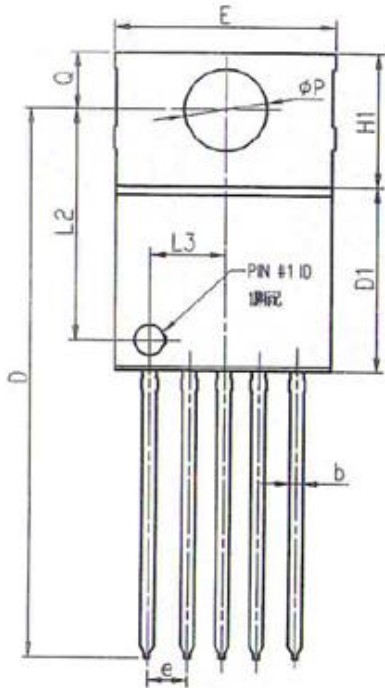

SYMBOL	MM			NDI		
	MIN	NDM	MAX	MIN	NDM	MAX
A	4.45	4.57	4.70	0.175	0.180	0.185
A1	1.22	1.27	1.32	0.048	0.050	0.052
A2	-	2.67	-	-	0.105	-
b	0.76	0.89	1.02	0.030	0.035	0.040
c	0.33	0.38	0.64	0.013	0.015	0.025
D	25.78	26.00	26.29	1.015	1.024	1.035
D1	8.38	8.70	8.89	0.330	0.343	0.350
E	10.13	10.26	10.39	0.399	0.404	0.409
E1	10.03	10.16	10.54	0.395	0.400	0.415
e	1.57	1.70	1.83	0.062	0.067	0.072
HI	6.10	6.35	6.60	0.240	0.250	0.260
L	13.34	13.74	14.10	0.525	0.541	0.555
L2	10.77REF			0.424REF		
L3	3.40REF			0.134REF		
phi P	3.78	-	3.89	0.149	-	0.153
phi P1	1.07	1.20	1.32	0.042	0.047	0.052
Q	2.54	-	3.05	0.100	-	0.120
theta 1	-	7°	-	-	7°	-
theta 2	-	3°	-	-	3°	-
theta 3	-	3°	-	-	3°	-
DEP	0.10	0.18	0.25	0.004	0.007	0.010

